

S71

S711-F655 Einbauspüle 180/450

Oberflächen: **Edelstahl** Artikelnummer: **43309800**



Beschreibung

Merkmale

- Material: Edelstahl
- Anzahl Becken: 1 Hauptbecken und 1 Zusatzbecken
- Hahnloch vorgebohrt
- Beckentiefe: 190 mm
- Unterschrank: 80 cm
- Einbauart: Flach aufliegend oder flächenbündig
- Position Überlauf: im Hauptbecken seitlich rechts
- Armaturenbankverstärkung für einen festen und stabilen Sitz der Armatur
- Eckradius: 10 mm

Zertifikate



Produktabbildung



Maßzeichnung

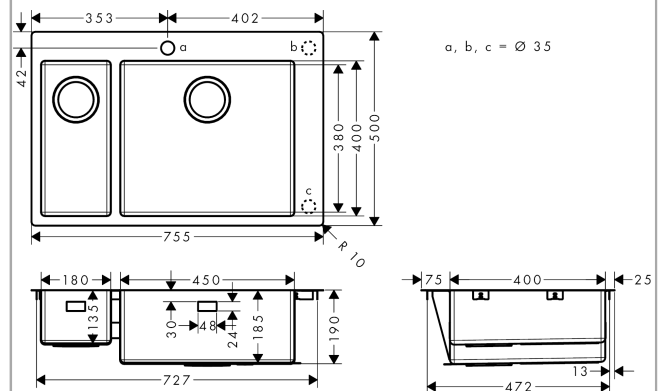

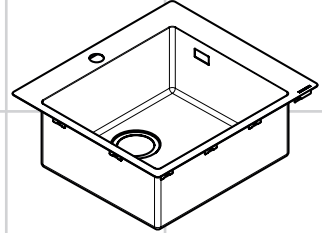

| | | | | |
|-----------|---|----|--------------------|------------------|
| DE | Gebrauchsanleitung / Montageanleitung | 2 | | |
| FR | Mode d'emploi / Instructions de montage | 2 | | |
| EN | Instructions for use / assembly instructions | 3 | | |
| IT | Istruzioni per l'uso / Istruzioni per Installazione | 3 | | |
| ES | Modo de empleo / Instrucciones de montaje | 4 | | |
| NL | Gebruiksaanwijzing / Handleiding | 4 | | |
| DK | Brugsanvisning / Monteringsvejledning | 5 | | |
| PT | Instruções para uso / Manual de Instalação | 5 | | |
| PL | Instrukcja obsługi / Instrukcja montażu | 6 | C71-F450-06 | S717-F450 |
| CS | Návod k použití / Montážní návod | 6 | 43201XXX | 43307800 |
| SK | Návod na použitie / Montážny návod | 7 | C71-F450-01 | S716-F450 |
| ZH | 用户手册 / 组装说明 | 7 | 43207XXX | 43331800 |
| RU | Руководство пользователя / Инструкция по монтажу | 8 | C71-F450-07 | S718-F450 |
| | | | 43205XXX | 43332800 |
| HU | Használati útmutató / Szerelési útmutató | 8 | C71-F450-02 | S711-F660 |
| | | | 43208XXX | 43302800 |
| FI | Käyttöohje / Asennusohje | 9 | C71-F450-11 | S712-F660 |
| SV | Brugsanvisning / Monteringsanvisning | 9 | 43229XXX | 43308800 |
| LT | Vartotojo instrukcija / Montavimo instrukcijos | 10 | C71-F450-12 | S711-F655 |
| HR | Upute za uporabu / Uputstva za instalaciju | 10 | 43230XXX | 43309800 |
| TR | Kullanım kılavuzu / Montaj kılavuzu | 11 | C71-F660-08 | S712-F655 |
| RO | Manual de utilizare / Instrucțiuni de montare | 11 | 43202XXX | 43310800 |
| EL | Οδηγίες χρήσης / Οδηγία συναρμολόγησης | 12 | C71-F660-03 | S711-F765 |
| SL | Navodilo za uporabo / Navodila za montažo | 12 | 43209XXX | 43303800 |
| ET | Kasutusjuhend / Paigaldusjuhend | 13 | C71-F655-09 | S712-F765 |
| | | | 43206XXX | 43311800 |
| LV | Lietošanas pamācība / Montāžas instrukcija | 13 | C71-F655-04 | S719-U400 |
| SR | Uputstvo za upotrebu / Uputstvo za montažu | 14 | 43210XXX | 43425800 |
| NO | Brugsanvisning / Montasjeveiledning | 14 | C71-F765-10 | S719-U450 |
| BG | Инструкция за употреба / Ръководство за монтаж | 15 | 43203XXX | 43426800 |
| | | | C71-F765-05 | S719-U500 |
| SQ | Udhëzuesi i përdorimit / Udhëzime rreth montimit | 15 | 43211XXX | 43427800 |
| AR | دليل الاستخدام / تعليمات التجميع | 16 | S711-F450 | S719-U660 |
| | | | 43301800 | 43428800 |
| | | | S712-F450 | S719-U655 |
| | | | 43305800 | 43429800 |
| | | | S715-F450 | S719-U765 |
| | | | 43306800 | 43430800 |



Sicherheitshinweise

- Bei der Montage müssen zur Vermeidung von Quetsch- und Schnittverletzungen Handschuhe getragen werden.

Montagehinweise

- Vor der Montage muss das Produkt auf Transportschäden untersucht werden. Nach dem Einbau werden keine Transport- oder Oberflächenschäden anerkannt.
- Die in den Ländern jeweils gültigen Installationsrichtlinien sind einzuhalten.
- Beim Einbau der Unterbauspülen in Arbeitsplatten aus Natur- oder Kunststein, Keramik oder Glas müssen die mitgelieferten Dübel mit geeignetem Kleber fixiert werden.

Symbolerklärung



Kein essigsäurehaltiges Silikon verwenden!



Maße (siehe Seite 17)



Sonderzubehör (nicht im Lieferumfang enthalten, siehe Seite 33)
 Befestigungssatz 10 - 35 mm #40950000
 Befestigungssatz 30 - 55 mm #40951000



Reinigung (siehe Seite 37)



Aufliegende Montage
siehe Seite 32



Bündige Montage siehe Seite 34



Unterbaumontage
siehe Seite 36



Consignes de sécurité

- Lors du montage, porter des gants de protection pour éviter toute blessure par écrasement ou coupure.

Instructions pour le montage

- Avant son montage, s'assurer que le produit n'a subi aucun dommage pendant le transport. Après le montage, tout dommage de transport ou de surface ne pourra pas être reconnu.
- Les directives d'installation en vigueur dans le pays concerné doivent être respectées.
- Pour le montage d'éviers encastrés dans des plans de travail en pierre naturelle ou artificielle, céramique ou verre, les chevilles livrées doivent être fixées à l'aide d'une colle appropriée.

Description du symbole



Ne pas utiliser de silicone contenant de l'acide acétique!



Dimensions (voir pages 17)



Accessoires en option (ne fait pas partie de la fourniture, voir pages 33)
 set de fixation 10 - 35 mm #40950000
 set de fixation 30 - 55 mm #40951000



Nettoyage (voir pages 37)



Montage en appui
voir pages 32



Montage affleurant
voir pages 34



Montage sous plan
voir pages 36



Safety Notes

- △ Gloves should be worn during installation to prevent crushing and cutting injuries.

Installation Instructions

- Prior to installation, inspect the product for transport damages. After it has been installed, no transport or surface damage will be honoured.
- The plumbing codes applicable in the respective countries must be observed.
- For installation of the underbuild unit sink in countertops made of natural or artificial stone, ceramics or glass, the dowels comprised in the delivery must be glued in with a suitable adhesive.

Symbol description



Do not use silicone containing acetic acid!



Dimensions (see page 17)



Special accessories (order as an extra, see page 33)
mounting kit 10 - 35 mm #40950000
mounting kit 30 - 55 mm #40951000



Cleaning (see page 37)



Surface-mounted installation see page 32



Flush installation see page 34



Undermount installation see page 36

Indicazioni sulla sicurezza

- △ Durante il montaggio, per evitare ferite da schiacciamento e da taglio bisogna indossare guanti protettivi.

Istruzioni per il montaggio

- Prima del montaggio è necessario controllare che non ci siano stati danni durante il trasporto. Una volta eseguito il montaggio, non verranno riconosciuti eventuali danni di trasporto o delle superfici.
- Vanno rispettate le direttive di installazione nazionali vigenti nel rispettivo paese.
- Al montaggio dei lavelli ad incasso in piani di lavoro di pietra naturale o artificiale, ceramica o vetro, fissare assolutamente i tasselli in dotazione con adeguata colla.

Descrizione simbolo



Non utilizzare silicone contenente acido acetico!



Ingombri (vedi pagg. 17)



Accessori speciali (non contenuto nel volume di fornitura, vedi pagg. 33)
set di fissaggio 10 - 35 mm #40950000
set di fissaggio 30 - 55 mm #40951000



Pulitura (vedi pagg. 37)



Montaggio appoggiato vedi pagg. 32



Montaggio a filo vedi pagg. 34



Montaggio a incasso vedi pagg. 36



Indicaciones de seguridad

- ⚠ Durante el montaje deben utilizarse guantes para evitar heridas por aplastamiento o corte.

Indicaciones para el montaje

- Antes del montaje se debe examinarse el producto contra daños de transporte. Después de la instalación no se reconoce ningún daño de transporte o de superficie.
- Es obligatorio el cumplimiento de las directrices de instalación vigentes en el país respectivo.
- Para el montaje bajo encimera del fregadero en planchas de piedra natural y artificial, cerámica o vidrio es necesario fijar los tacos suministrados con una cola adecuada.

Descripción de símbolos



No utilizar silicona que contiene ácido acético!



Dimensiones (ver página 17)



Opcional (no incluido en el suministro, ver página 33)

Set de fijación 10 - 35 mm #40950000

Set de fijación 30 - 55 mm #40951000



Limpiar (ver página 37)



Montaje superpuesto
ver página 32



Montaje a ras ver página 34



Montaje rebajado ver página 36



Veiligheidsinstructies

- ⚠ Bij de montage moeten ter voorkoming van knel- en snijwonden handschoenen worden gedragen.

Montage-instructies

- Vóór de montage moet het product gecontroleerd worden op transportschade. Na de inbouw wordt geen transport- of oppervlakteschade meer aanvaard.
- De in de overeenkomstige landen geldende installatierichtlijnen moeten nageleefd worden.
- Bij de inbouw van onderbouwspoelbakken in werkbladen van natuursteen of kunststof, keramiek of glas moeten de meegeleverde bouten vastgezet worden met geschikte lijm.

Symboolbeschrijving



Gebruik geen zuurhoudende silicone!



Maten (zie blz. 17)



Toebehoren (behoort niet tot het leveringspakket, zie blz. 33)

bevestigingsmateriaal 10 - 35 mm

#40950000

bevestigingsmateriaal 30 - 55 mm

#40951000



Reinigen (zie blz. 37)



Opbouw montage zie blz. 32



Vlakke montage zie blz. 34



Onderbouw montage zie blz. 36



⚠ Sikkerhedsanvisninger

⚠ Ved monteringen skal der bruges handsker for at undgå kvæstelser og snitsår.

Monteringsanvisninger

- Før monteringen skal produktet kontrolleres for transportskader. Efter monteringen godkendes transportskader eller skader på overfladen ikke længere.
- Installationsbestemmelserne, der gælder i det enkelte land, skal overholdes.
- Ved montering af underlimede køkkenvaske i bordplader af natur- eller kunststen, keramik eller glas skal de medfølgende dybler fastgøres med en egnet lim.

Symbolbeskrivelse



Der må ikke benyttes eddikesyreholdig silikone!



Målene (se s. 17)



Specialtilbehør (ikke med i leveringsomfang, se s. 33)
Befæstigelsesdele 10 - 35 mm #40950000
Befæstigelsesdele 30 - 55 mm #40951000



Rengøring (se s. 37)



Udvendigt liggende montering se s. 32



Plan montering se s. 34



Undermonteret montage se s. 36

⚠ Avisos de segurança

⚠ Durante a montagem devem ser utilizadas luvas de protecção, de modo a evitar ferimentos resultantes de entalamentos e de cortes.

Avisos de montagem

- Antes da montagem deve-se controlar o produto relativamente a danos de transporte. Após a montagem não são aceites quaisquer danos de transporte ou de superfície.
- A prescrições de instalação válidas nos respetivos países devem ser respeitadas.
- Na instalação dos lava-loiças em bancadas de pedra natural, pedra artificial, cerâmica ou vidro, as buchas fornecidas devem ser fixadas com cola adequada para o efeito.

Descrição do símbolo



Não utilizar silicone que contenha ácido acético!



Medidas (ver página 17)



Acessórios especiais (não incluído no volume de fornecimento, ver página 33)
Set de fixação 10 - 35 mm #40950000
Set de fixação 30 - 55 mm #40951000



Limpeza (ver página 37)



Montagem de cima ver página 32



Montagem alinhada ver página 34



Montagem por baixo ver página 36

**! Wskazówki bezpieczeństwa**

- ! Aby uniknąć zranień na skutek zgniecenia lub przecięcia, podczas montażu należy nosić rękawice ochronne.

Wskazówki montażowe

- Przed montażem należy skontrolować produkt pod kątem szkód transportowych. Po montażu nie widać żadnych szkód transportowych ani szkód na powierzchni.
- Należy przestrzegać wytycznych instalacyjnych obowiązujących w danym kraju.
- Przy montażu zlewu wpuszczanego w płytkach roboczych z kamienia naturalnego lub z tworzywa sztucznego, ceramiki lub szkła należy zamocować dostarczone kołki przy użyciu odpowiedniego kleju.

Opis symbolu

Nie stosować silikonów zawierających kwas octowy!



Wymiary (patrz strona 17)



Wyposażenie specjalne (Nie jest częścią dostawy, patrz strona 33)
Zestaw mocujący 10 - 35 mm #40950000
Zestaw mocujący 30 - 55 mm #40951000



Czyszczenie (patrz strona 37)



Montaż na blacie
patrz strona 32



Montaż w jednej linii z blatem
patrz strona 34



Montaż pod blatem
patrz strona 36

! Bezpečnostní pokyny

- ! Pro zabránění řezným zraněním a pohmožděním je nutné při montáži nosit rukavice.

Pokyny k montáži

- Před montáží je třeba produkt zkontrolovat, zda nebyl při transportu poškozen. Po zabudování nebudou uznány žádné škody způsobené transportem nebo poškození povrchu.
- Je třeba dodržovat montážní pravidla platné v dané zemi.
- Při montáži dřezů do pracovních desek z přírodního a umělého kamene, keramiky nebo skla je nutné přiložené hmoždinky upevnit vhodným lepidlem.

Popis symbolů

Nepoužívat silikon s obsahem kyseliny octové!



Rozměry (viz strana 17)



Zvláštní příslušenství (není součástí dodávky, viz strana 33)
montážní sada 10 - 35 mm #40950000
montážní sada 30 - 55 mm #40951000



Čištění (viz strana 37)



Vestavná montáž na desku
viz strana 32



Zarovnaná montáž
viz strana 34



Spodní montáž
viz strana 36



! Bezpečnostné pokyny

- ! Pri montáži musíte nosiť rukavice, aby ste predišli pomliaždeninám a rezným poraneniam.

Pokyny pre montáž

- Pred montážou musíte produkt skontrolovať, či nebol počas transportu poškodený. Po zabudovaní nebudú uznané žiadne škody spôsobené transportom alebo poškodenia povrchu.
- Je potrebné dodržiavať smernice o inštalácii, ktoré sú práve teraz platné v krajinách.
- Pri montáži zabudovaných výleviek do pracovných dosiek z prírodného alebo umelého kameňa, keramiky alebo skla musíte dodané hmoždinky zaistiť pomocou vhodného lepidla.

Popis symbolov



Nepoužívať silikón s obsahom kyseliny octovej!



Rozmery (viď strana 17)



Zvláštne príslušenstvo (nie je súčasťou dodávky, viď strana 33)
montážna súprava 10 - 35 mm #40950000
montážna súprava 30 - 55 mm #40951000



Čistenie (viď strana 37)



Montáž nasadením zvrchu viď strana 32



Montáž do jednej roviny viď strana 34



Montáž nasadením zospodu viď strana 36

! 安全技巧

- ! 装配时为避免挤压和切割受伤，必须戴上手套。

安装提示

- 安装前必须检查产品是否受到运输损害。安装后将不认可运输损害或表面损伤。
- 请遵守当地国家现行的安装规定。
- 在由天然石材或人造石材、陶瓷或玻璃制成的工作台安装底层地板时，必须用合适的胶固定所提供的销钉。

符号说明



请勿使用含有乙酸的硅胶！



大小 (参见第页 17)



选装附件 (不在供货范围内, 参见第页 33)
安装套件 10 - 35 mm #40950000
安装套件 30 - 55 mm #40951000



清洗 (参见第页 37)



表面贴装 参见第页 32



嵌入式安装 参见第页 34



台下安装 参见第页 36



Указания по технике безопасности

-  Во время монтажа следует надеть перчатки во избежание прищемления и порезов.

Указания по монтажу

- Перед монтажом следует проверить изделие на предмет повреждений при перевозке. После монтажа претензии о возмещении ущерба за повреждения при перевозке или повреждения поверхностей не принимаются.
- Необходимо соблюдать требования по монтажу, действующие в соответствующих странах.
- Если встраиваемые раковины встраиваются в столешницы из натурального или искусственного камня, керамики или стекла, дюбели, входящие в комплект, нужно зафиксировать при помощи специального клея.

Описание символов



Не применяйте силикон, содержащий уксусную кислоту.



Размеры (см. стр. 17)



Специальные принадлежности (не включено в объем поставки!, см. стр. 33)

крепежный набор 10 - 35 мм
#40950000

крепежный набор 30 - 55 мм
#40951000



Очистка (см. стр. 37)



Монтаж на поверхности см. стр. 32



Монтаж на одном уровне см. стр. 34



Встраиваемая конструкция см. стр. 36

Biztonsági utasítások

-  A szerelésnél a zúzódások és vágási sérülések elkerülése érdekében kesztyűt kell viselni.

Szerelési utasítások

- A szerelés előtt ellenőrizni kell, hogy a terméknek nincs-e szállítási sérülése. Beépítés után a szállítási- vagy felületi sérüléseket nem ismerik el.
- Az egyes országokban érvényes installációs irányelveket be kell tartani.
- A természetes- vagy műkö, kerámia vagy üveg munkalapba alulról beépített mosogatók beszerelésekor a mellékelt tipliket megfelelő ragasztóval rögzíteni kell.

Szimbólumok leírása



Ne használjon ecetsavtartalmú szilikont!



Méretet (lásd a oldalon 17)



Egyéb tartozék (a szállítási egység nem tartalmazza, lásd a oldalon 33)

Rögzítő felület 10 - 35 mm #40950000

Rögzítő felület 30 - 55 mm #40951000



Tisztítás (lásd a oldalon 37)



Felfekvő szerelés lásd a oldalon 32



Egy síkban szerelés lásd a oldalon 34



Aláépített szerelés lásd a oldalon 36



Turvallisuusohjeet

- Asennuksessa on käytettävä käsiineitä puristumien ja viiltojen aiheuttamien tapaturmien estämiseksi.

Asennusohjeet

- Ennen asennusta on tarkastettava tuotteen mahdolliset kuljetusvahingot. Asennuksen jälkeen kuljetus- ja pintavaurioita ei hyväksytä.
- Jokaisessa maassa on noudatettava siellä päteviä asennusohjeita.
- Kun päällysvälyn alle kiinnitettävät tiskialtaat kiinnitetään luonnon- tai keinokiviin, keramiisiin tai lasisiin levymateriaaleihin, mukana toimitetut kiinnitystapit on kiinnitettävä soveltuvalla liimalla.

Merkin kuvaus



Älä käytä etikkahappopitoista silikonial!



Mitat (katso sivu 17)



Eritysisvaruste (ei kuulu toimitukseen, katso sivu 33)

Kiinnityssarja 10 - 35 mm #40950000

Kiinnityssarja 30 - 55 mm #40951000

Säkerhetsanvisningar

- Handskar ska bäras under monteringsarbetet så att man kan undvika kläm- och skärskadorgen werden.

Monteringsanvisningar

- Det måste undersökas om produkten har transportskador innan den monteras. Efter monteringen accepteras inga transport- eller ytskiktsskador.
- De installationsriktlinjer som gäller i länderna ska följas.
- Om vaskar ska monteras i arbetsbänkar av natursten, plastmaterial, keramik eller glas måste medföljande dyblar fixeras med lämpligt lim.

Symbolförklaring



Använd inte silikon som innehåller ättiksyra!



Måtten (se sidan 17)



Specialtillbehör (medföljer ej leveransen, se sidan 33)

Monteringssats 10 - 35 mm #40950000

Monteringssats 30 - 55 mm #40951000



Puhdistus (katso sivu 37)



Rengöring (se sidan 37)



Asennus pinnan päälle katso sivu 32



Påliggande montering se sidan 32



Asennus pinnan taan katso sivu 34



Montering i linje se sidan 34



Asennus levyn alle katso sivu 36



Infälld montering se sidan 36



Saugumo technikos nurodymai

- ⚠️ Apsaugai nuo užspaudimo ir įsijpavimo montavimo metu mūvėkite pirštines.

Montavimo instrukcija

- Prieš montuojant būtina patikrinti, ar gaminy nebuvu pažeistas transportavimo metu. Sumontavus pretenzijos dėl transportavimo ir paviršiaus pažeidimų nepriimamos.
- Laikykitės atitinkamoje šalyje galiojančių direktyvų dėl įrengimo.
- Montuojant įleidžiamas plautuves į natūralaus ar dirbtinio akmens, keramikos ar stiklo stalviršius, tinkamai klijuais turi būti pritvirtinti patiekli kaiščiai.

Simbolio aprašymas



Nenaudokite silikono, kurio sudėtyje yra acto rūgšties!



Išmatavimai (žr. psl. 17)



Specialūs priedai (nėra pridedama, žr. psl. 33)

Prijungimo komplektas 10 - 35 mm
#40950000

Prijungimo komplektas 30 - 55 mm
#40951000



Valymas (žr. psl. 37)



Montavimas ant viršaus žr. psl. 32



Montavimas suleidžiant žr. psl. 34



Montavimas įleidžiant gilyn žr. psl. 36

Sigurnosne upute

- ⚠️ Prilikom montaže se radi sprječavanja prignječenja i posjekotina moraju nositi rukavice.

Upute za montažu

- Prije montaže mora se provjeriti je li proizvod oštećen prilikom transporta. Nakon ugradnje se ne priznaju nikakve reklamacije koje se odnose na površinska i transportna oštećenja.
- Obvezno se moraju uvažiti propisi o instalacijama koji vrijede u dotičnoj zemlji.
- Za ugradnju podžbuknog sudopera u radne ploče od prirodnog ili umjetnog kamena, keramike ili stakla, isporučene moždanike treba pričvrstiti odgovarajućim ljepliom.

Opis simbola



Nemojte koristiti silikon koji sadrži octenu kiselinu!



Mjere (pogledaj stranicu 17)



Posebni pribor (Nije sadržano u isporuci!, pogledaj stranicu 33)

garnitura za pričvršćivanje 10 - 35 mm
#40950000

garnitura za pričvršćivanje 30 - 55 mm
#40951000



Čišćenje (pogledaj stranicu 37)



Nadpultna montaža pogledaj stranicu 32



Montaža u ravnini pogledaj stranicu 34



Podpultna montaža pogledaj stranicu 36



! Güvenlik uyarıları

- ! Montaj esnasında ezilme ve kesilme gibi yaralanmalara önlemek için eldiven kullanılmalıdır.

Montaj açıklamaları

- Montaj işleminden önce ürün nakliye hasarları yönünden kontrol edilmelidir. Montaj işleminden sonra nakliye veya yüzey hasarları için sorumluluk üstlenilmemektedir.
- Ülkelerde geçerli kurulum yönetmeliklerine riayet edilmelidir.
- Gömme evyeleri, doğal veya yapay taştan, seramik veya cam çalışma tezgahlarına monte ederken birlikte teslim edilen dübeller uygun bir yapıştırıcıyla sabitlenmelidir.

Simge açıklaması



Asetik asit içeren silikon kullanmayın!



Ölçüleri (bakınız sayfa 17)



Özel aksesuarlar (Teslimat kapsamına dahil değildir, bakınız sayfa 33)
Sabitleme seti 10 - 35 mm #40950000
Sabitleme seti 30 - 55 mm #40951000



Temizleme (bakınız sayfa 37)



Tezgah üzerinde montaj bakınız sayfa 32



Tezgaha sıfır montaj bakınız sayfa 34



Tezgah altı montaj bakınız sayfa 36

! Instrucțiuni de siguranță

- ! La montare utilizați mănuși pentru evitarea contuziunilor și tăierii mâinilor.

Instrucțiuni de montare

- Înainte de instalare verificați, dacă produsul prezintă deteriorări de transport. După instalare garanția nu acoperă deteriorările de transport și cele de suprafață.
- Respectați reglementările referitoare la instalare valabile în țara respectivă.
- La montarea chiuvetelor încorporate în blaturile de piatră naturală sau artificială, de ceramică sau sticlă trebuie să fixați diblurile incluse în furnitură cu un adeziv corespunzător.

Descrierea simbolurilor



Nu utilizați silicon cu conținut de acid acetic!



Dimensiuni (vezi pag. 17)



Accesorii opționale (nu este inclus în setul livrat, vezi pag. 33)
Garnitură de fixare 10 - 35 mm #40950000
Garnitură de fixare 30 - 55 mm #40951000



Curățare (vezi pag. 37)



Montare deasupra blatului vezi pag. 32



Montare la nivel cu blatul vezi pag. 34



Montare sub blat vezi pag. 36

**⚠ Υποδείξεις ασφαλείας**

- ⚠ Για να αποφύγετε τραυματισμούς κατά τη συναρμολόγηση πρέπει να φοράτε γάντια.

Οδηγίες συναρμολόγησης

- Πριν τη συναρμολόγηση πρέπει να εξεταστεί το προϊόν για ζημιές μεταφοράς. Μετά την εγκατάσταση δεν αναγνωρίζονται ζημιές από τη μεταφορά ή επιφανειακές ζημιές.
- Θα πρέπει να τηρούνται οι οδηγίες εγκατάστασης που ισχύουν σε κάθε κράτος.
- Κατά την τοποθέτηση του νεροχύτη κάτω από πάγκους εργασίας από φυσικό ή συνθετικό μάρμαρο, κεραμική ή γυάλινη επιφάνεια πρέπει τα βύσματα που παραδίδονται μαζί να στερεώνονται με κατάλληλη κόλλα.

Περιγραφή συμβόλων

Μην χρησιμοποιείτε σιλικόνη που περιέχει οξικό οξύ!



Διαστάσεις (βλ. Σελίδα 17)



Ειδικά αξεσουάρ (δεν περιλαμβάνεται στον παραδοτέο εξοπλισμό, βλ. Σελίδα 33)

Ομάδα στηριγμάτων στερέωσης 10 - 35 mm #40950000

Ομάδα στηριγμάτων στερέωσης 30 - 55 mm #40951000



Καθαρισμός (βλ. Σελίδα 37)



Τοποθέτηση επάνω στον πάγκο εργασίας
βλ. Σελίδα 32



Τοποθέτηση πρόσωπο με τον πάγκο εργασίας
βλ. Σελίδα 34



Τοποθέτηση κάτω από τον πάγκο εργασίας
βλ. Σελίδα 36

⚠ Varnostna opozorila

- ⚠ Pri montaži je treba nositi rokavice, da se preprečijo poškodbe zaradi zmečkanja ali urezov.

Navodila za montažo

- Pred montažo je treba izdelek preveriti glede morebitnih transportnih poškodb. Po vgradnji transportne ali površinske poškodbe ne bodo več priznane.
- Upoštevati je treba pravilnike o inštalacijah, ki veljajo v posamezni državi.
- Pri vgradnji podpultnih umivalnikov v delovne plošče iz naravnega ali umetnega kamna, keramike ali stekla se morajo priloženi mozniki fiksirati s primernim lepilom.

Opis simbola

Ne smete uporabiti silikona, ki vsebuje ocetno kislino!



Mere (glejte stran 17)



Poseben pribor (Ni vključeno, glejte stran 33)

Pritrditveni komplet 10 - 35 mm #40950000

Pritrditveni komplet 30 - 55 mm #40951000



Čiščenje (glejte stran 37)



Naležna montaža
glejte stran 32



Poravnana montaža
glejte stran 34



Podometna montaža
glejte stran 36



Ohutusjuhised

- △ Kandke paigaldamisel muljumis- ja löikevigastuste vältimiseks kindaid.

Paigaldamisjuhised

- Enne paigaldamist tuleb toodet kontrollida transportdikahjustuste osas Pärast paigaldamist ei tunnustata enam transporti- või pinnakahjustuste kaebuseid.
- Vastavas riigis kehtivaid paigalduseeskirju tuleb järgida.
- Kraanikausaluse kapi paigaldamisel naturaalsest või kunstkiivist, keraamilise või klaasist tööpinna alla tuleb kaasa antud tüüblid fikseeritud sobiva kleebisega.

Sümbolite kirjeldus



Ärge kasutage äädikhapet sisaldavat silikooni!



Mõõtude (vt lk 17)



Spetsiaalne lisavarustus (ei sisaldu komplektis, vt lk 33)
paigaldus komplekt 10 - 35 mm
#40950000

paigaldus komplekt 30 - 55 mm
#40951000



Puhastamine (vt lk 37)



Pealepaigaldus vt lk 32



Kohakuti paigaldus vt lk 34



Allapaigaldus vt lk 36

Drošības norādes

- △ Montāžas laikā, lai izvairītos no saspiedumiem un iegriezumiem, nepieciešams nēsāt cimdus.

Norādījumi montāžai

- Pirms montāžas nepieciešams pārbaudīt, vai produktam transportēšanas laikā nav radušies bojājumi. Pēc iebūvēšanas bojājumi, kas radušies transportēšanas laikā, vai virsmas bojājumi netiek atzīti.
- Jāievēro attiecīgās valsts spēkā esošās montāžas prasības.
- Iebūvējot izlietni galda virsmā no dabīgā vai mākslīgā akmens, keramikas vai stikla, komplektā esošie dībeļi jānofiksē ar piemērotu līmi.

Simbolu nozīme



Neizmantojot silikonu, kas satur etiķskābi!



Izmērus (skat. lpp. 17)



Speciāli aksesuāri (komplektā netiek piegādāts, skat. lpp. 33)
Stiprinājuma komplekts 10 - 35 mm
#40950000

Stiprinājuma komplekts 30 - 55 mm
#40951000



Tīršana (skat. lpp. 37)



Montāža uz virsmas skat. lpp. 32



Montāža vienā līmei skat. lpp. 34



Iebūvējama konstrukcija skat. lpp. 36

**! Sigurnosne napomene**

- ! Prilikom montaže se radi sprečavanja prignječena i posekotina moraju nositi rukavice.

Instrukcije za montažu

- Pre montaže se mora proveriti da li je proizvod oštećen pri transportu. Nakon ugradnje se ne priznaju nikakve reklamacije koje se odnose na površinska i transportna oštećenja.
- Treba se pridržavati propisa koji u određenim zemljama važe za instalacije.
- Prilikom ugradnje podpultnih sudopera ispod radne ploče od prirodnog ili veštačkog kamena, keramike ili stakla, isporučeni moždanici moraju se fiksirati odgovarajućim lepkom.

Opis simbola

Nemojte koristiti silikon koji sadrži sirćetnu kiselinu!



Mere (vidi stranu 17)



Poseban pribor (Nije sadržano u isporuci, vidi stranu 33)

garnitura za pričvršćivanje 10 - 35 mm
#40950000

garnitura za pričvršćivanje 30 - 55 mm
#40951000



Čišćenje (vidi stranu 37)



Nadpultna montaža
vidi stranu 32



Nadovezujuća
montaža vidi stranu 34



Podpultna montaža
vidi stranu 36

! Sikkerhetshenvisninger

- ! Bruk hanser under montasjen for å unngå klem- og kuttskader.

Montagehenvisninger

- Før montasjen skal produktet sjekkes for transportskader. Etter monteringen aksepteres ikke noen transport- eller overflateskader.
- Gjeldende retningslinjer for rørleggerarbeid i de enkelte land skal følges.
- Ved montering av undermontert vask i benkplater av natur- eller kunststein, keramikk eller glass må de medfølgende pluggene festes med egnet lim.

Symbolbeskrivelse

Ikke bruk silikon som inneholder eddiksyre!



Mål (se side 17)



Ekstratilbehør (ikke med i leveransen, se side 33)

Festesett 10 - 35 mm #40950000

Festesett 30 - 55 mm #40951000



Rengjøring (se side 37)



utenpåliggende
montering se side 32



flush montering se side 34



underliggende montering se side 36



Указания за безопасност

- При монтажа трябва да се носят ръкавици, за да се избегнат наранявания поради притискане или порязване.

Указания за монтаж

- Преди монтажа продуктът трябва да се провери за транспортни щети. След монтажа не се признават транспортни или повърхностни щети.
- Трябва да бъдат спазвани валидните в съответните страни предписания за инсталиране.
- При монтажа на вградени мивки в работни плотове от естествен или изкуствен камък, керамика или стъкло доставените дюбели трябва да бъдат фиксирани с подходящо лепило.

Описание на символите



Не използвайте силикон, съдържащ оцетна киселина!



Размери (вижте стр. 17)



Специални принадлежности
(не се съдържа в обема на доставката, вижте стр. 33)

Комплект за закрепване 10 - 35 мм
#40950000

Комплект за закрепване 30 - 55 мм
#40951000



Почистване (вижте стр. 37)



лежаш монтаж вижте стр. 32



плътен монтаж вижте стр. 34



монтаж под мазилка вижте стр. 36

Udhëzime sigurie

- При монтажа трябва да се носят ръкавици, за да се избегнат наранявания поради притискане или порязване.

Udhëzime për montimin

- Përpara montimit duhet që produkti të kontrollohet për dëmtime nga transporti. Pas instalimit nuk do të njihet asnjë dëmtim nga transporti ose dëmtim i sipërfaqes.
- Duhet të respektohen linjat udhëzuese të instalimit, të vlefshme për vendet respektive.
- Gjatë montimit të lavapjatatave inkaso në pllakat e vendosjes prej guri natyror ose artificial, qeramike ose xhami duhet që upat e lëvuara të fiksohen me ngjitës të përshtatshëm.

Përshkrimi i simbolit



Mos përdorni silikon që në përbërje ka acid acetik.



Përmasat (shih faqen 17)



Pajisje të posaçme (nuk përfshihet në vëllimin e furnizimit, shih faqen 33)

Pajisja përforcuese 10 - 35 mm
#40950000

Pajisja përforcuese 30 - 55 mm #40951000



Pastrimi (shih faqen 37)



Monti i vendosur shih faqen 32



Montim i bashkuar shih faqen 34



Montim nën strukturë shih faqen 36



⚠️ تنبيهات الأمان

⚠️ يجب إرتداء قفازات لليد أثناء التركيب لتجنب حدوث أخطار الإنحشار أو الجروح.

تعليمات التركيب

- قبل القيام بعملية التركيب، يجب فحص المنتج للتأكد من خلوّه من أية تلفيات ناتجة عن النقل. بعد القيام بعملية التركيب، لن يتم الاعتراف بوجود أية تلفيات سطحية أو تلفيات ناتجة عن عملية النقل.
- يجب مراعاة القواعد الخاصة بالتركيب وأعمال السباكة وفقاً للوائح الخاصة بكل بلد.
- عند تركيب أحواض التركيب السفلي في أسطح العمل المصنوعة من الحجر الطبيعي أو الأصدناعي، أو السيراميك أو الزجاج فإنه يجب تثبيت الخوابير المرفقة باستخدام مادة لاصقة مناسبة.

وصف الرمز

هام! لا تستخدم السليكون الذي يحتوي على أمماض!



أبعاد (راجع صفحة 17)



ملحقات خاصة (غير مدرج مع المحتويات المسلمة، راجع صفحة 33)
مجموعة التثبيت 10 - 35 مم #40950000
مجموعة التثبيت 30 - 55 مم #40951000



التنظيف (راجع صفحة 37)



التركيب الفوقي راجع صفحة

32



التركيب المستوي راجع

صفحة 34



التركيب التحتي راجع صفحة

36



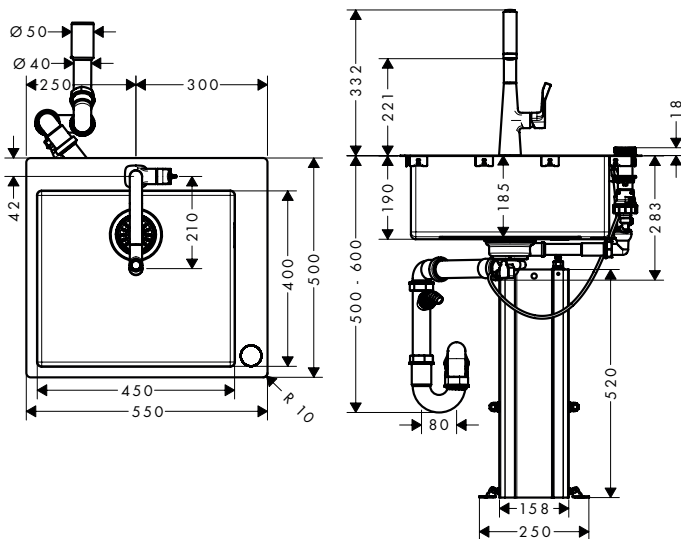
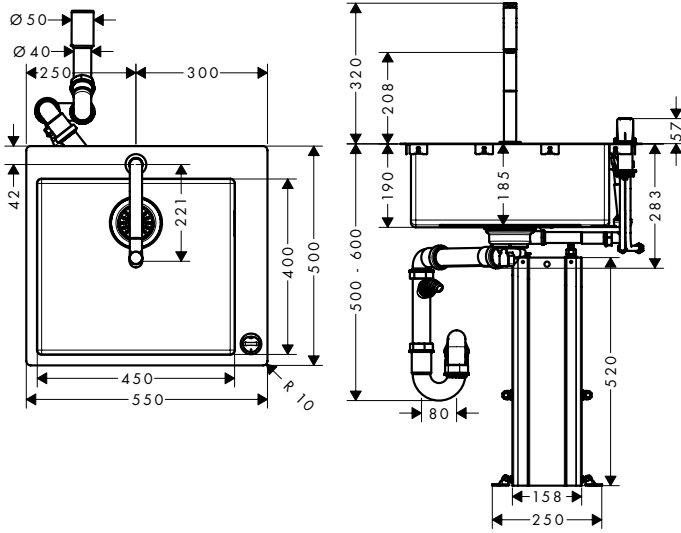
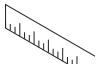

C71-F450-07 43205XXX

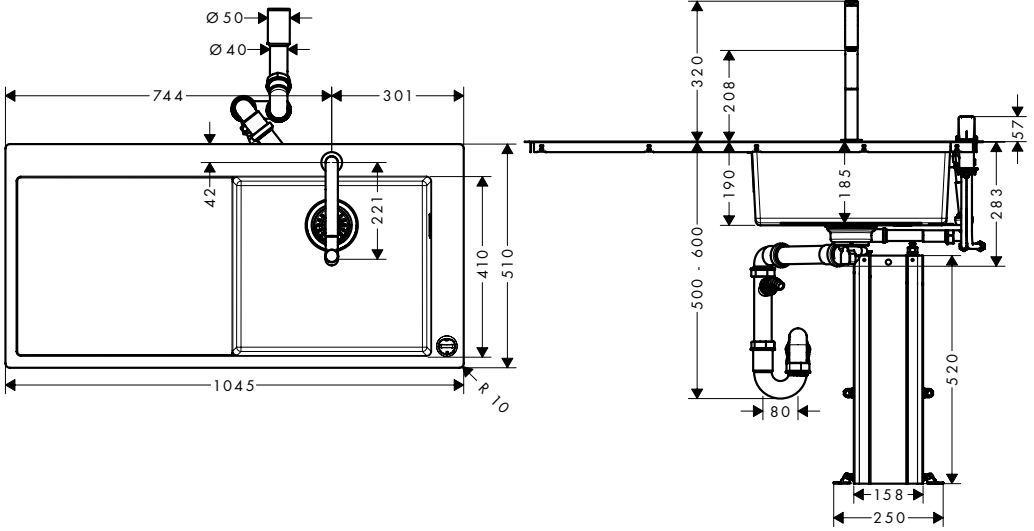

C71-F450-02 43208XXX

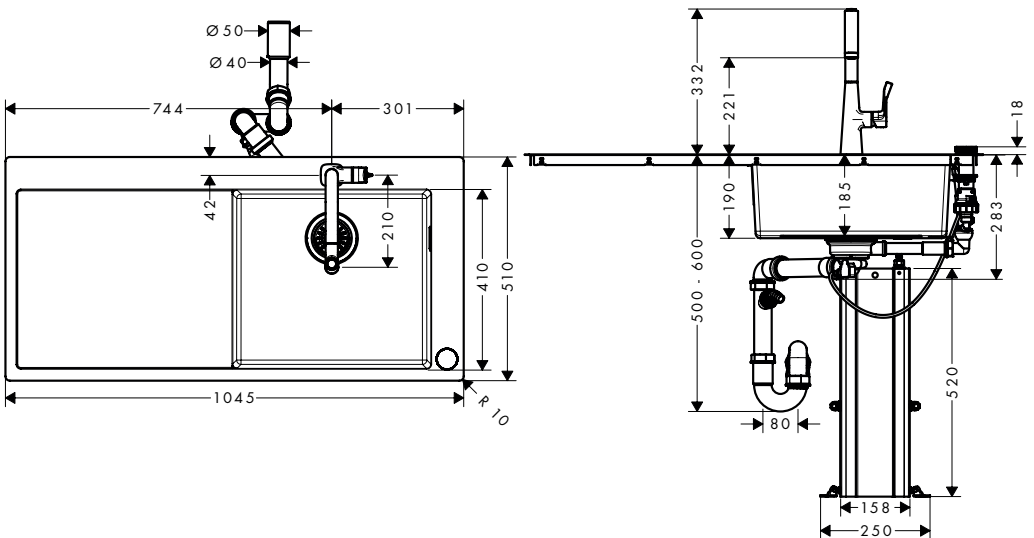

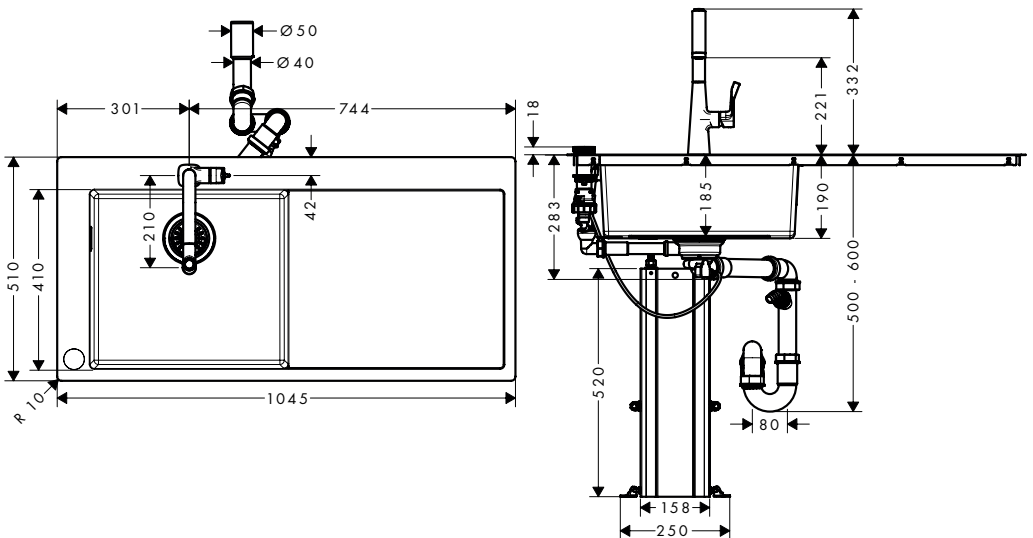
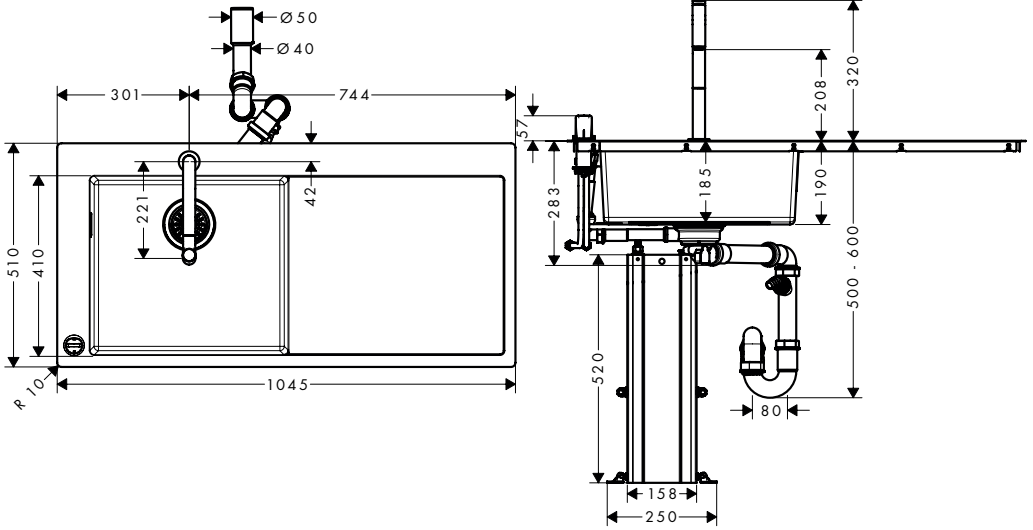
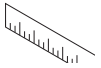

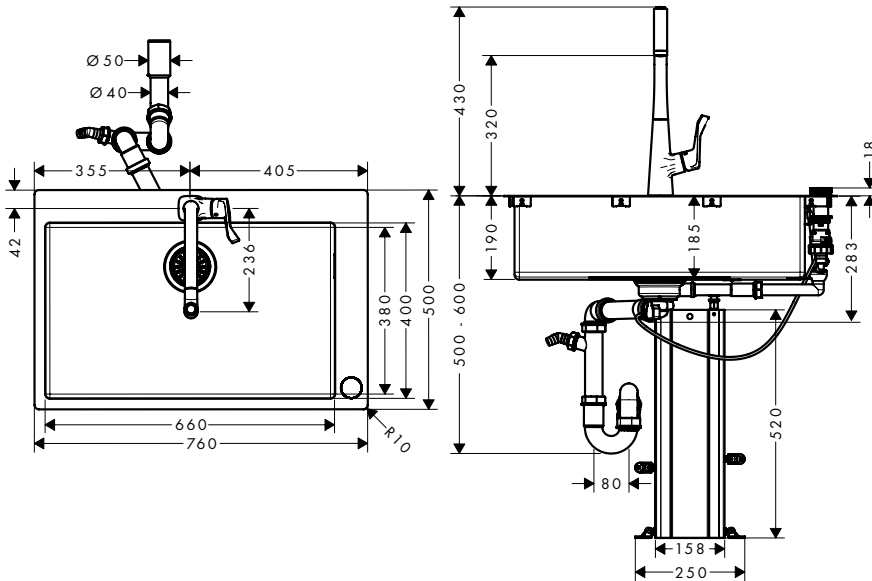
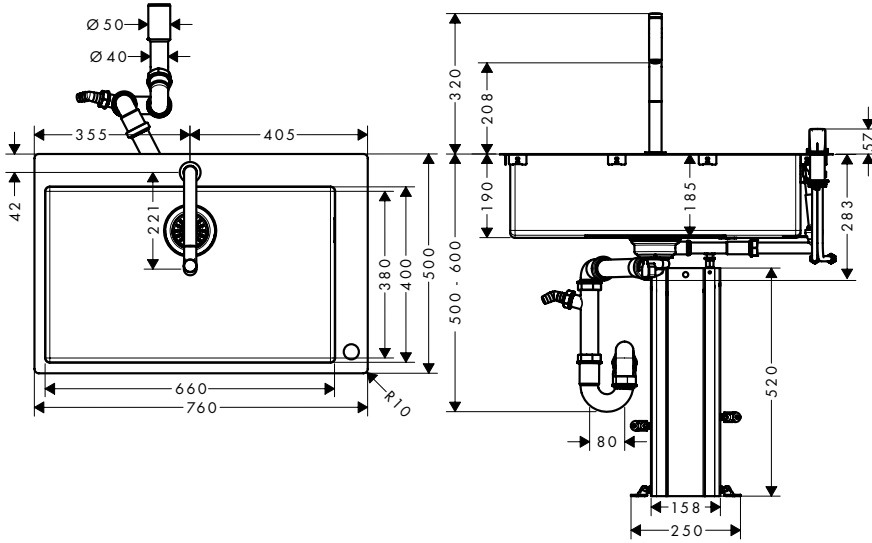
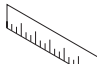

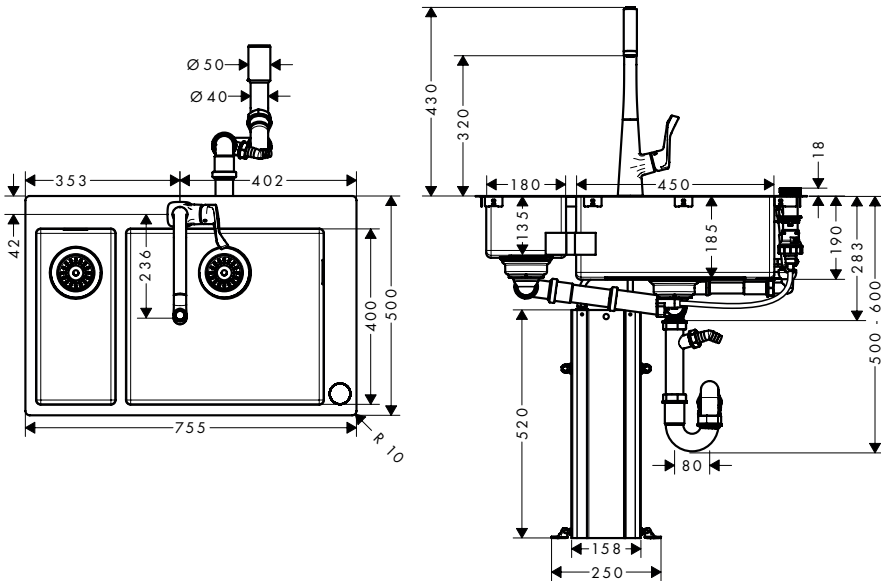
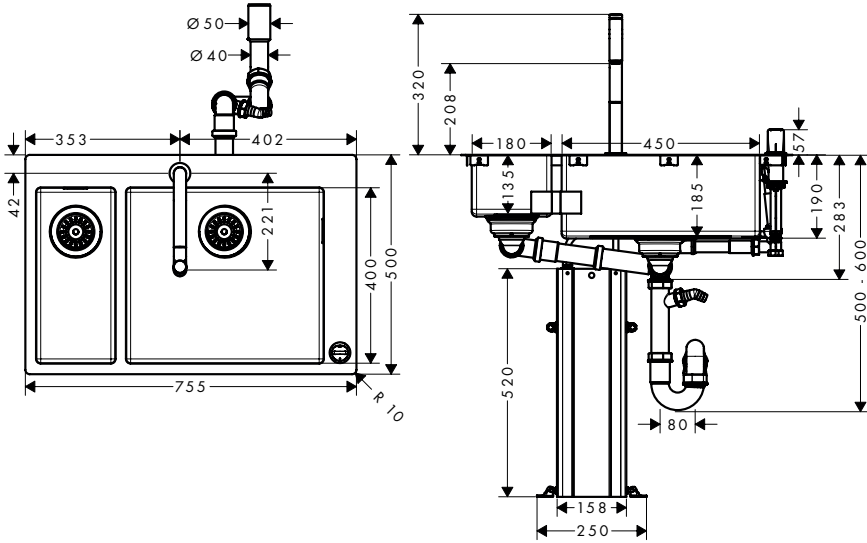
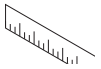

C71-F765-10 43203XXX

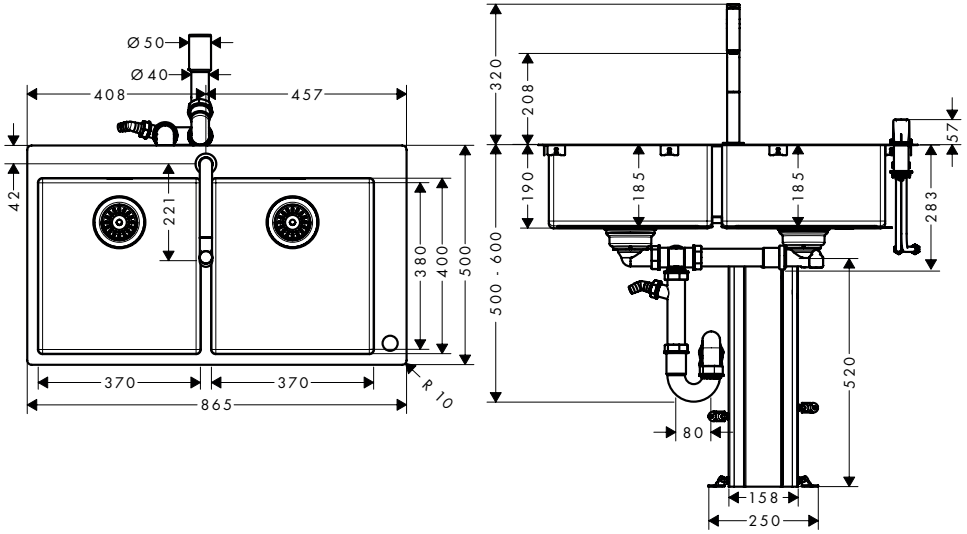

C71-F765-05 43211XXX

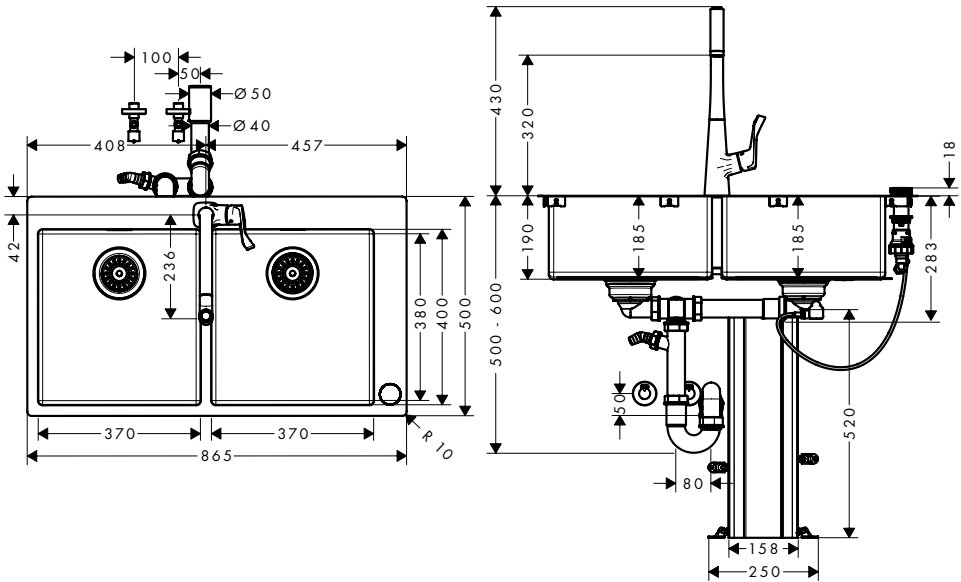

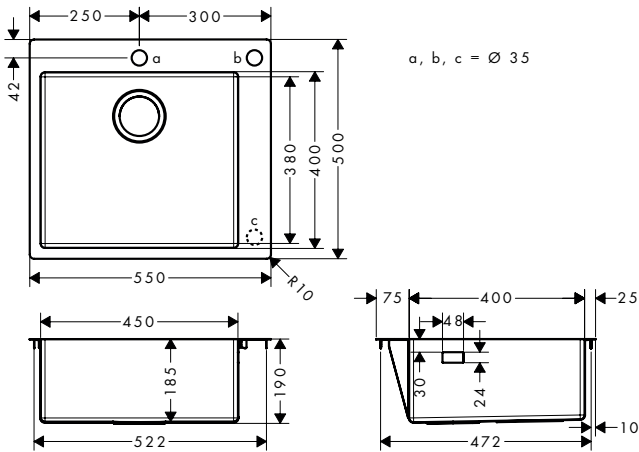
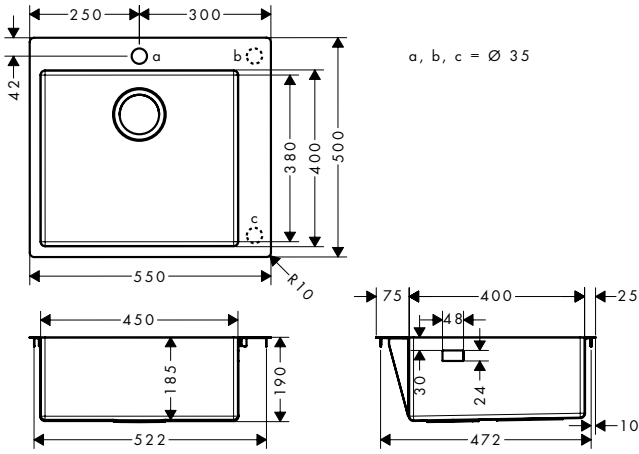
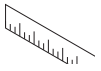

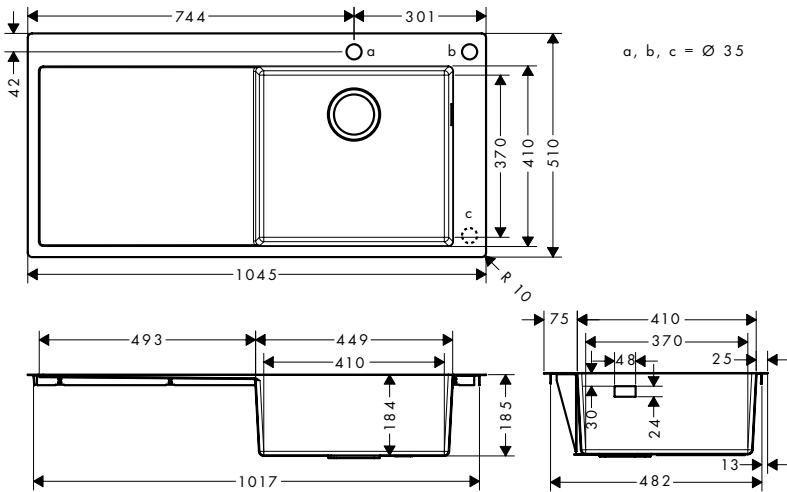
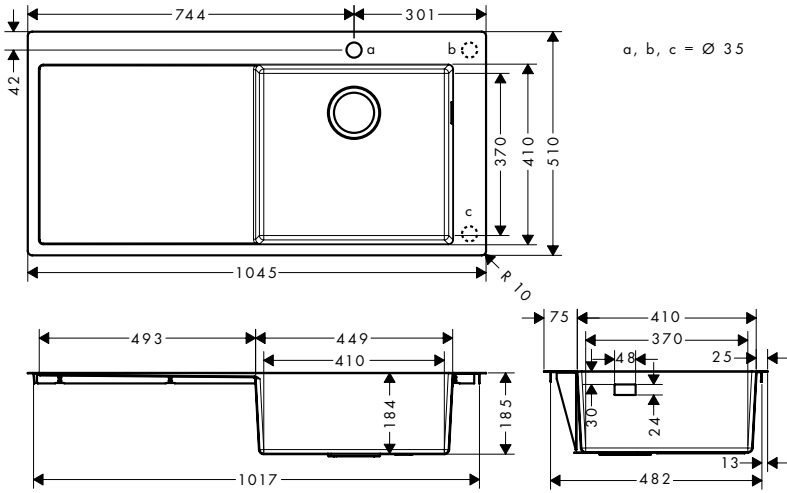

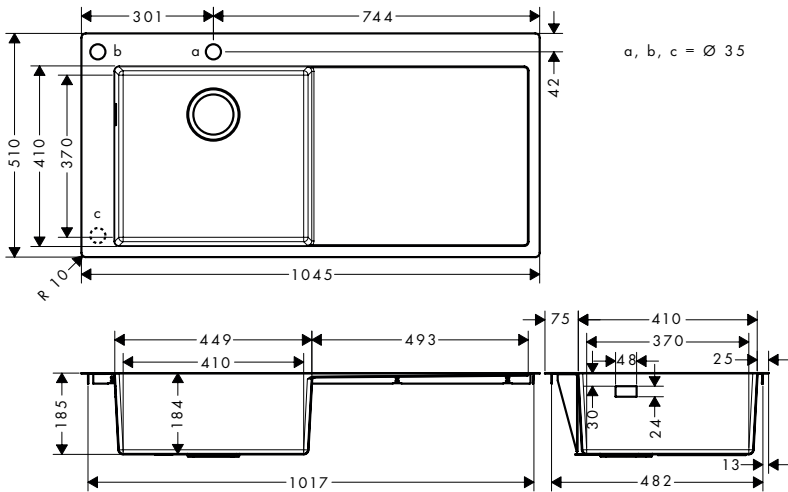
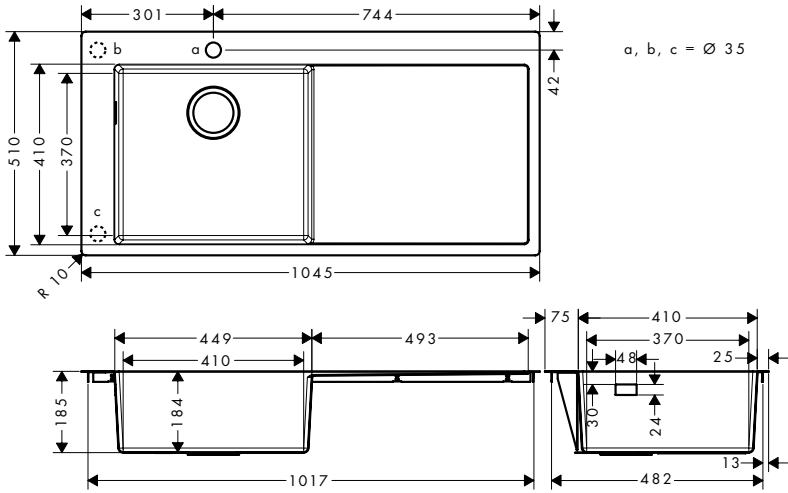
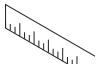

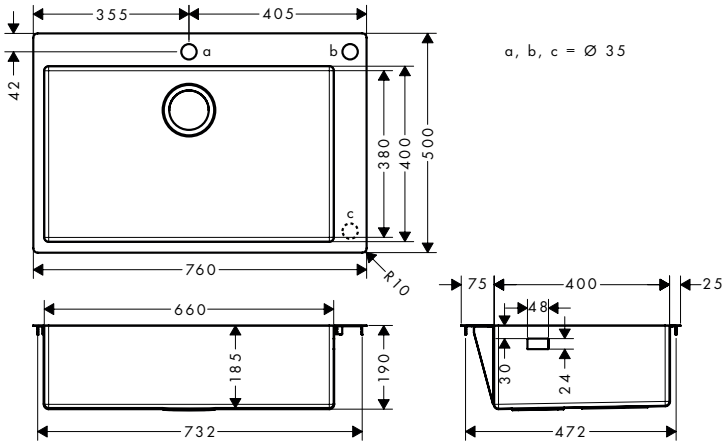
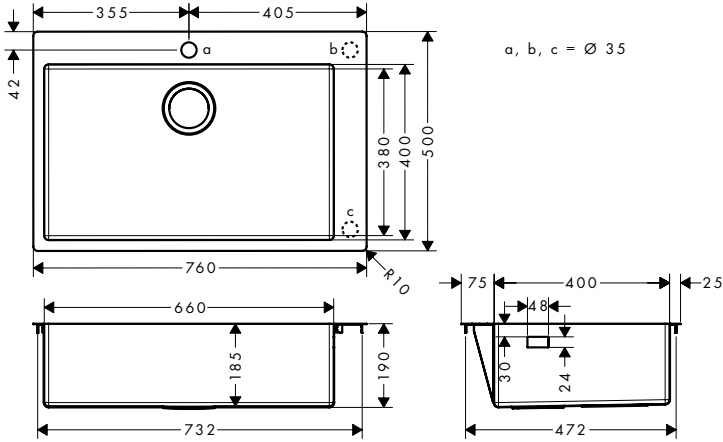

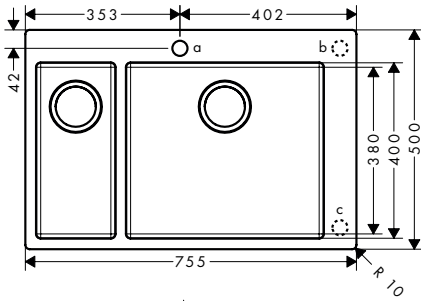
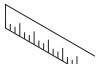

a, b, c = \varnothing 35

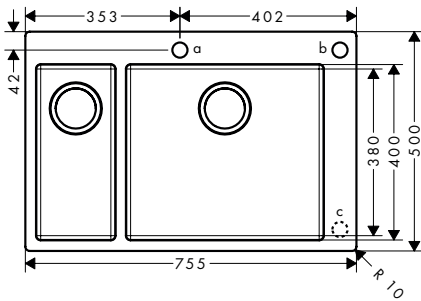
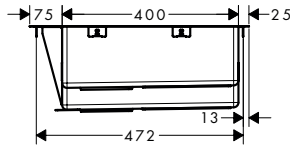
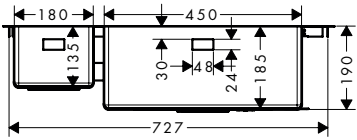

a, b, c = \varnothing 35

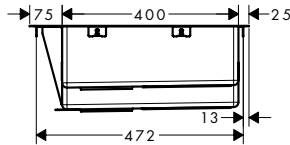
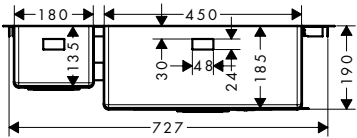

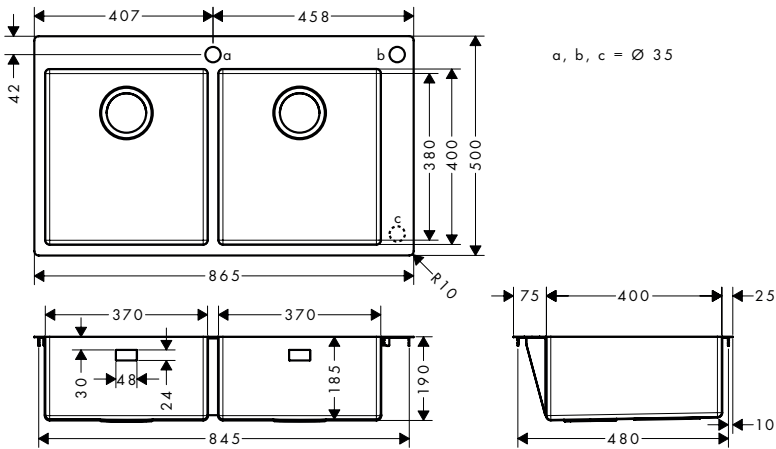
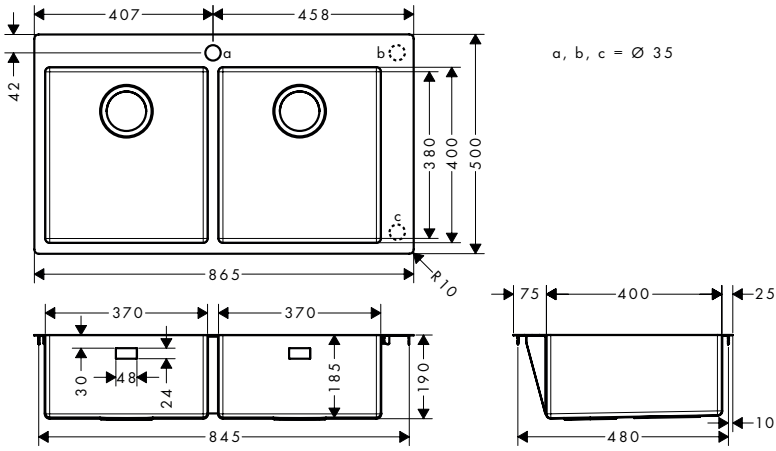

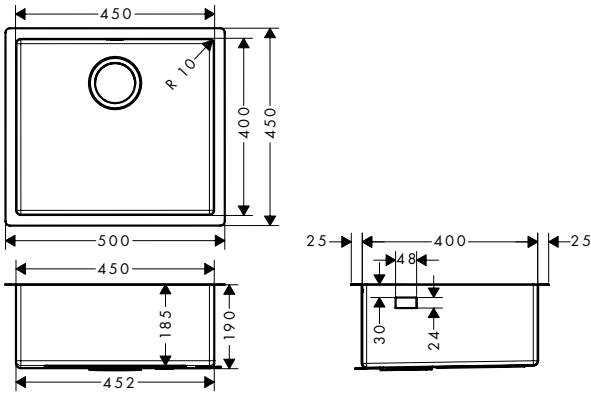
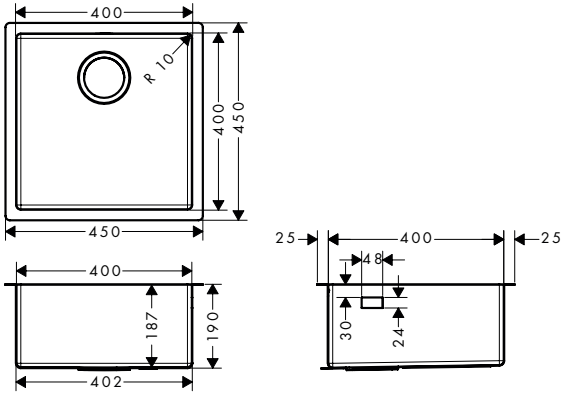
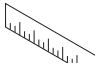

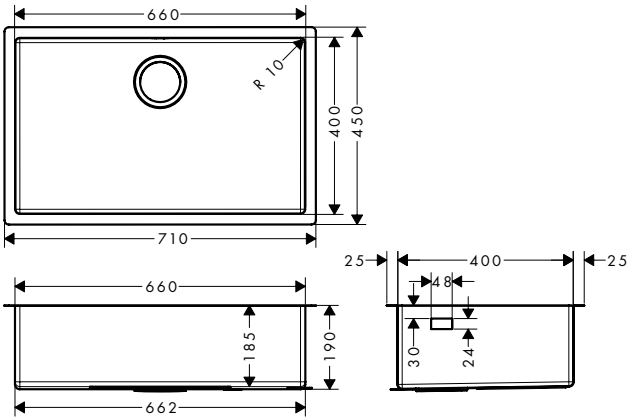
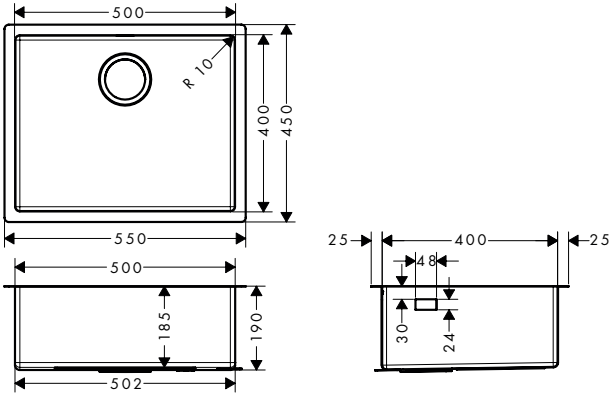

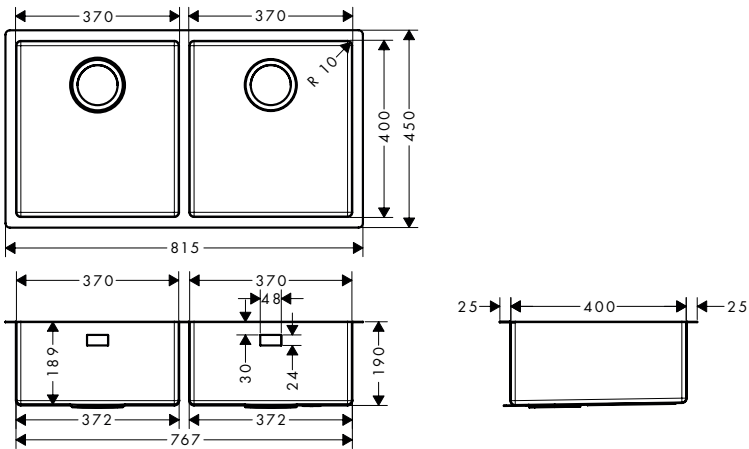
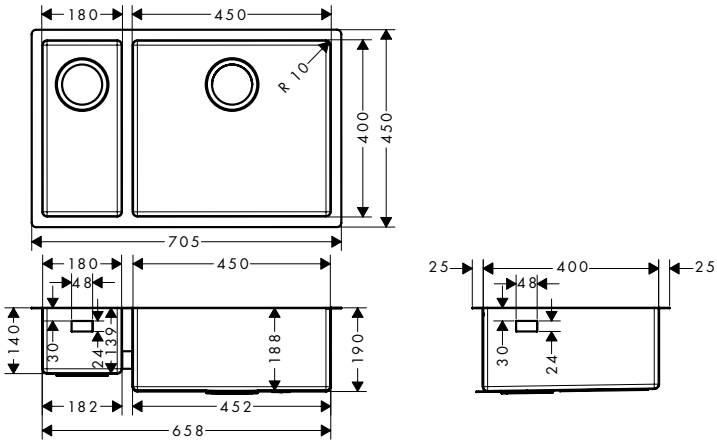
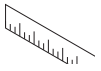

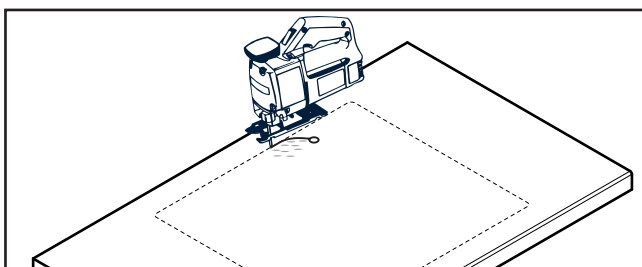
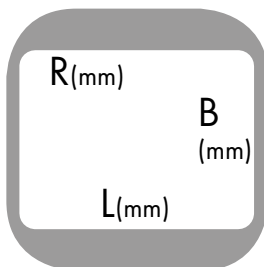
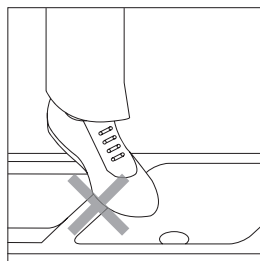
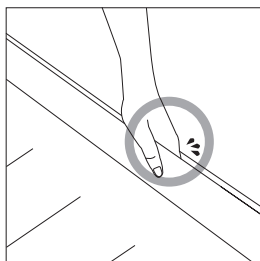
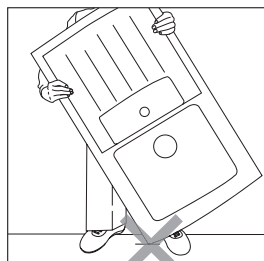

| | | L | B | R |
|--|--|------|-----|--------|
| C71-F450-06 43201XXX C71-F450-01 43207XXX S711-F450 43301800 S712-F450 43305800 | | 530 | 480 | 0 - 10 |
| C71-F660-08 43202XXX C71-F660-03 43209XXX S711-F660 43302800 S712-F660 43308800 | | 740 | 480 | 0 - 10 |
| C71-F765-10 43203XXX C71-F765-05 43211XXX S711-F765 43303800 S712-F765 43311800 | | 845 | 480 | 0 - 10 |
| C71-F655-09 43206XXX C71-F655-04 43210XXX S711-F655 43309800 S712-F655 43310800 | | 735 | 480 | 0 - 10 |
| C71-F450-07 43205XXX C71-F450-02 43208XXX S715-F450 43306800 S717-F450 43307800 | | 1025 | 490 | 0 - 10 |
| C71-F450-11 43229XXX C71-F450-12 43230XXX S716-F450 43331800 S718-F450 43332800 | | 1025 | 490 | 0 - 10 |

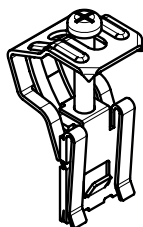
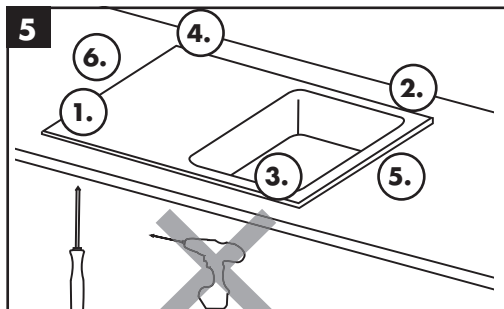
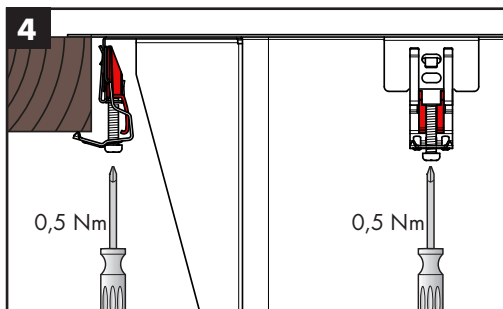
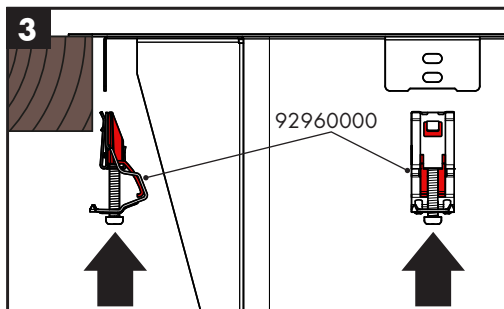
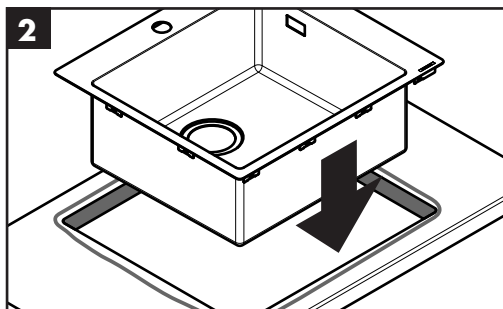
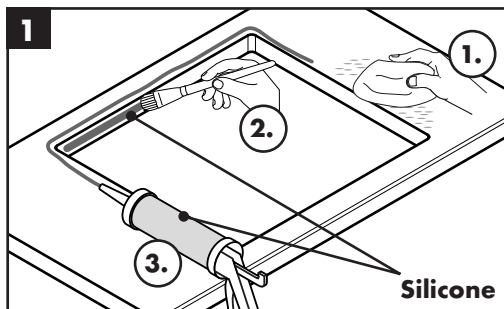

92960000 28 - 40 mm

40950000 10 - 35 mm

40951000 30 - 55 mm



| | | L ¹ | L ² | B ¹ | B ² | R |
|--|--|----------------|----------------|----------------|----------------|----|
| C71-F450-06 43201XXX C71-F450-01 43207XXX S711-F450 43301800 S712-F450 43305800 | | 530 | 552 | 480 | 502 | 11 |
| C71-F660-08 43202XXX C71-F660-03 43209XXX S711-F660 43302800 S712-F660 43308800 | | 740 | 762 | 480 | 502 | 11 |
| C71-F765-10 43203XXX C71-F765-05 43211XXX S711-F765 43303800 S712-F765 43311800 | | 845 | 867 | 480 | 502 | 11 |
| C71-F655-09 43206XXX C71-F655-04 43210XXX S711-F655 43309800 S712-F655 43310800 | | 735 | 757 | 480 | 502 | 11 |
| C71-F450-07 43205XXX C71-F450-02 43208XXX S715-F450 43306800 S717-F450 43307800 | | 1025 | 1047 | 490 | 512 | 11 |
| C71-F450-11 43229XXX C71-F450-12 43230XXX S716-F450 43331800 S718-F450 43332800 | | 1025 | 1047 | 490 | 512 | 11 |
| S719-U400 43425800 | | 430 | 452 | 430 | 452 | 11 |
| S719-U450 43426800 | | 480 | 502 | 430 | 452 | 11 |
| S719-U500 43427800 | | 530 | 552 | 430 | 452 | 11 |
| S719-U660 43428800 | | 690 | 712 | 430 | 452 | 11 |
| S719-U655 43429800 | | 685 | 707 | 430 | 452 | 11 |
| S719-U765 43430800 | | 795 | 817 | 430 | 452 | 11 |

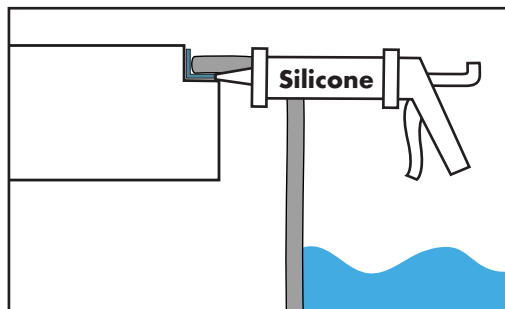
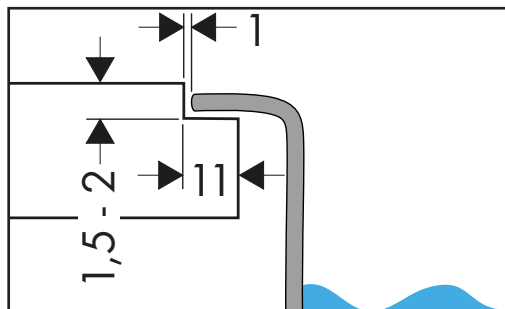
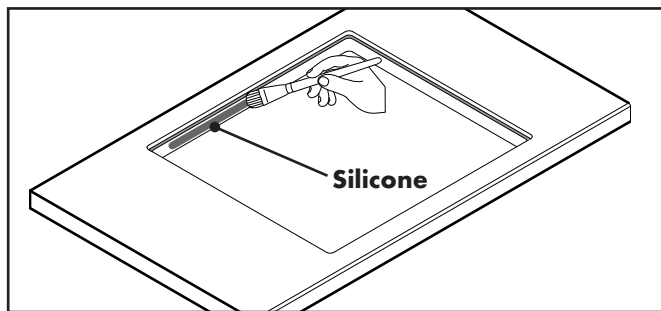
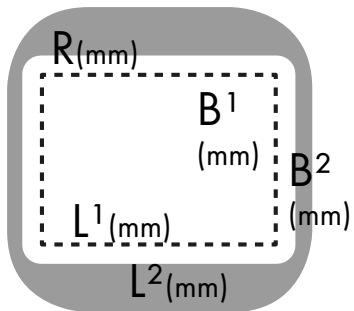

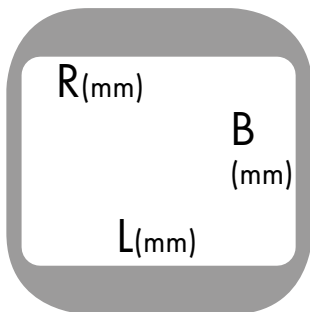

| | | L | B | R |
|---------------------------|--|-----|-----|---|
| S719-U400 43425800 | | 398 | 398 | 8 |
| S719-U450 43426800 | | 448 | 398 | 8 |
| S719-U500 43427800 | | 498 | 398 | 8 |
| S719-U660 43428800 | | 658 | 398 | 8 |
| S719-U655 43429800 | | 653 | 398 | 8 |
| S719-U765 43430800 | | 763 | 398 | 8 |

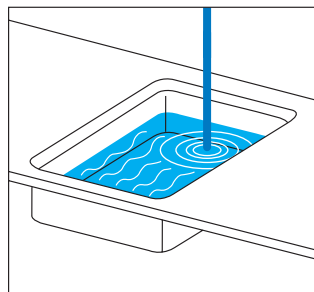
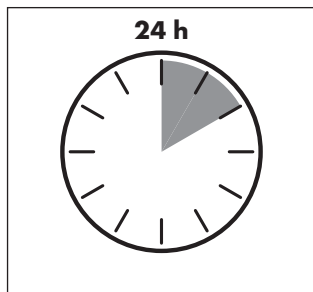
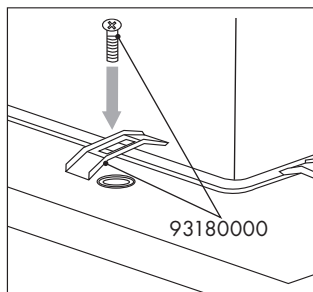
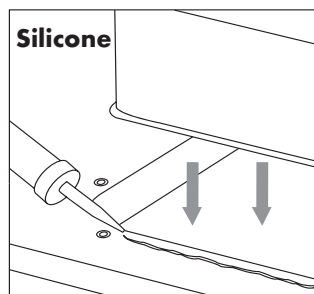
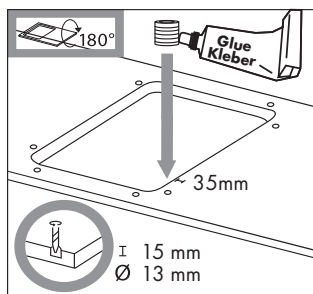
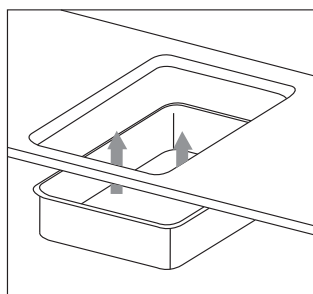

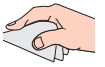

- DE** Reinigungsempfehlung / Garantie / Kontakt
- FR** Recommandation pour le nettoyage / Garanties / Contact
- EN** Cleaning recommendation / Warranty / Contact
- IT** Raccomandazione di pulizia / Garanzia / Contatto
- ES** Recomendaciones para la limpieza / Garantía / Contacto
- NL** Aanbevelingen inzake reiniging / Garantie / Contact
- DK** Rensning, anbefaling / Garanti / Kontakt
- PT** Recomendações de limpeza / Garantia / Contacto
- PL** Zalecenie dotyczące pielęgnacji / Gwarancja / Kontakt
- CS** Doporučení k čištění / Záruka / Kontakt
- SK** Odporúčania pre čistenie / Záruka / Kontakt
- ZH** 清洁指南 / 担保 / 接触
- RU** Рекомендации по очистке / Гарантия / Контакты
- HU** Tisztítási tanácsok / Garancia / érintkezés
- FI** Puhdistussuositus / Takuu / Kosketus
- SV** Rengöringsrekommendationer / Garanti / Contacto
- LT** Valymo rekomendacijos / Garantija / Kontaktai
- HR** Preporuke za čišćenje / Garancija / Kontakt
- TR** Temizleme önerisi / Garanti / Temas
- RO** Recomandări pentru curățare / Garanție / Contact
- EL** Σύσταση καθαρισμού / Εγγύηση / επαφή
- SL** Priporočilo za čiščenje / Garancija / Kontakt
- ET** Puhastussoovitused / Garantii / Kontakt
- LV** Tīrīšanas ieteikumi / Garantija / Kontakti
- SR** Preporuke za čišćenje / Garancija / Kontakt
- NO** Anbefaling for rengjøring / Garanti / Kontakt
- BG** Препоръка за почистване / Гаранция / Контакт
- SQ** Këshilla rreth pastrimit / Garancia / Kontakt
- KO** 세정시 권장사항 / 품질보증 / 접촉
- AR** توصيات التنظيف / الضمان (الولايات المتحدة الأمريكية) / اتصال



www.hansgrohe.com/cleaning-recommendation

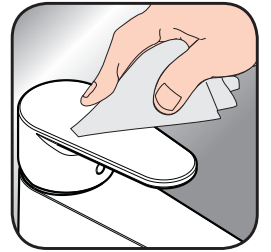

www.hansgrohe.com/cleaning-recommendation



www.hansgrohe.com/cleaning-recommendation



www.hansgrohe.com/cleaning-recommendation



hansgrohe

Hansgrohe · AuestraÙe 5 · 9 · D-77761 Schiltach · Telefon +49 (0) 78 36/51-1282 · Telefax +49 (0) 7836/511440
E-Mail: info@hansgrohe.com · Internet: www.hansgrohe.com

8/2018
9_04003_04